



Dolly Family

Minimizes replenishment cost

Maximizes in-store availability

- A revolutionary 'one-touch' dolly that functions as BOTH transport storage and as an attractive in-store display.
- Ideal for picking orders at your depot for direct to store.
- Designed to replace conventional shelving eliminating both time & cost of stacking while increasing sales due to constant product availability.
- Can be easily maneuvered, eliminating the need for dedicated handling equipment.
- Pop-up/rims system - to secure your trays and crates - upon request.
- Specially designed to nest on top of another - save on transportation and storage cost.
- Easy-to-clean polymer - resists moisture, insects and fungi; Impervious to acids, fats, solvents and odors.

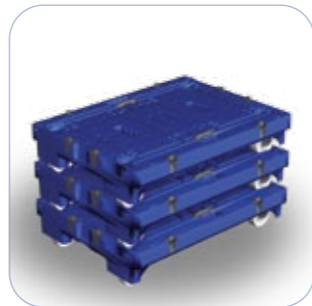

Technical details:

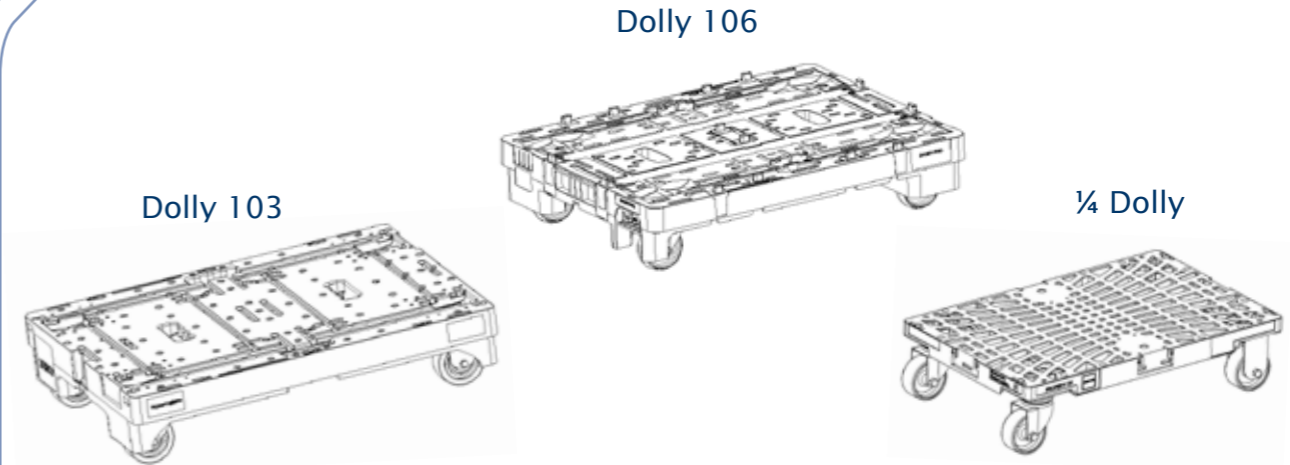

Dolly 103	Dolly 103	Dolly 106	¼ Dolly
Dimensions (LxWxH) / mm	800 X 600 X 180	800 X 600 X 175	600 X 400 X 150
Weight / Kg	10.9	9.5	4
Load Capacity / Kg	500	500	250
Material	PP	PP	PP
Brake		✓	
Pop-up	✓	✓	✓
Side rims	✓	✓	✓
Handle	✓	✓	
Antislid rubber	✓	✓	✓



Retail Ready Packaging
The ultimate in cost savings

www.polymerlogistics.com

* Polymer Logistics reserves the right to change any of the abovementioned specifications without prior notice

User Responsibility:

It is the responsibility of all users and hires to inform any other users concerning the details provided on this specifications sheet and the Polymer Logistics Health & Safety Guidelines. Users are responsible for completing Safe System Work and risk assessments prior to equipment use.