

The Crystal Clear Series



The new premium Crystal Clear series A new level of appearance!

- Highlights the product, not the package
- Cleaner, purer look - increases sales
- Huge cost reductions in store - minimizes replenishment time
- Higher availability - increases sales
- Robust construction - reduces product damage
- Environmentally friendly, fully recyclable
- Foldable and stackable - minimizes store and truck space
- Sustainable solution - replacing traditional disposable packaging
- Easy to clean polymer - resist moisture, insects and fungi; Impervious to acids, fats, solvents and odors.





Crystal Clear 409AL - Technical Details

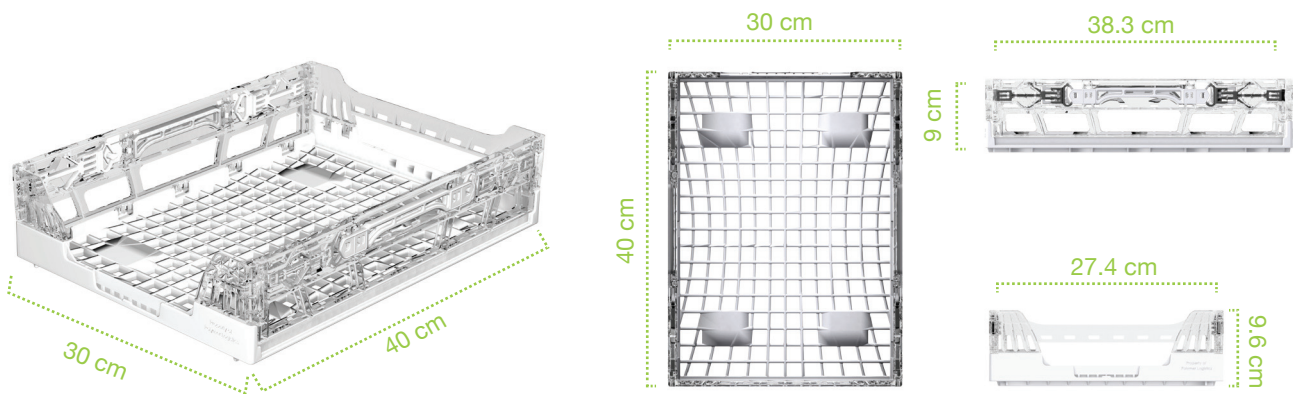

Dimensions

External: 40 x 30 x 9.6 cm

Internal: 38.3 x 27.4 x 8.7 cm

Folded: 40 x 30 x 3.5 cm

Weight: 0.75 kg

Volume: 9 liter

Load capacity: 7 kg

Stacking capacity: 154 kg



Retail Ready Packaging
The ultimate in cost savings



Crystal Clear 632AL - Technical Details

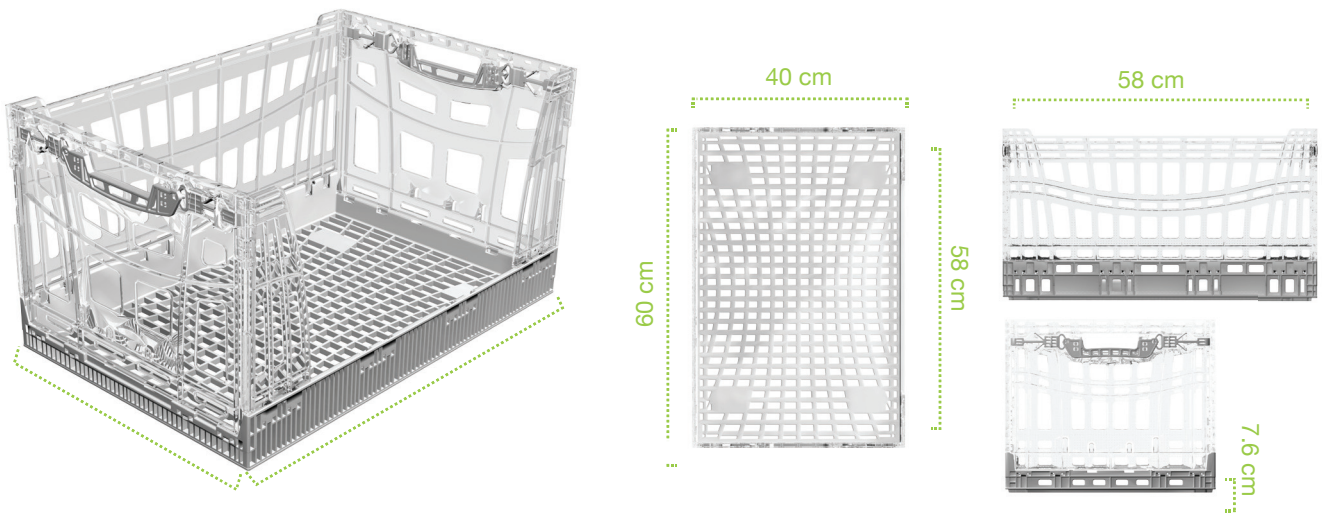

Dimensions

External: 60 x 40 x 32.9 cm

Internal: 58 x 38.5 x 32 cm

Folded: 60 x 40 x 7.6 cm

Weight: 2.2 kg

Volume: 71 liter

Load capacity: 10 kg

Stacking capacity: 70 kg

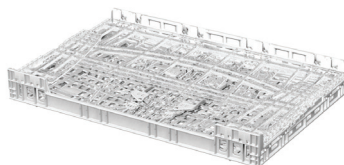

Retail Ready Packaging
The ultimate in cost savings

Elog & Tosca reserves the right to change any of the above mentioned specifications without prior notice.
user responsibility: It is the responsibility of all users and heirs to inform any other user concerning the details provided on this specifications sheet and the Elog & Tosca Health & Safety Guidelines. Users are responsible for completing Safe System Work and risk assessment prior to equipment use.