

1/2 Pallet

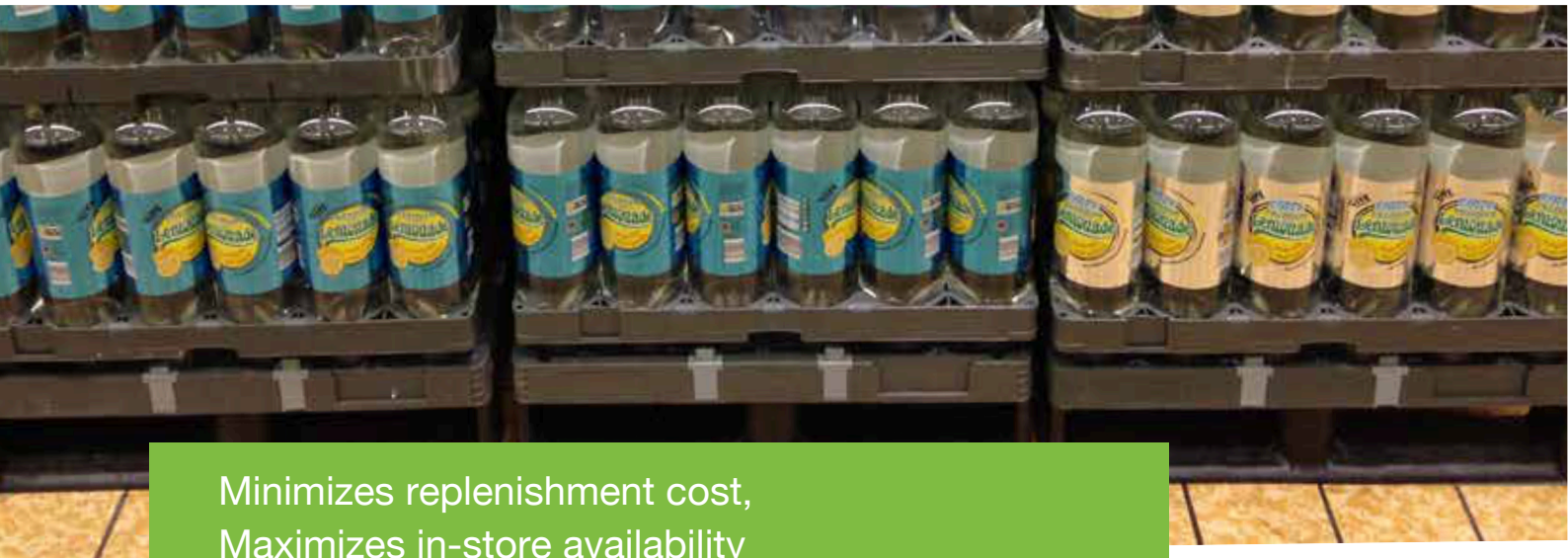

Minimizes replenishment cost, Maximizes in-store availability

- A revolutionary 'one-touch' pallet that functions both as transport & storage and as an attractive in-store display!
- Uniquely designed to replace traditional shelving, eliminating both the time & cost of merchandising shelves.
- Easy and secured nesting to maximize truck and storage space.
- Can be used on a roll conveyor.
- Pop up / Rim system - to secure your trays and crates (upon request).
Flat surface for flat goods.
- Easy-to-clean polymer, resists moisture, insects and fungi;
Impervious to acids, fats, solvents and odor.





Technical Details

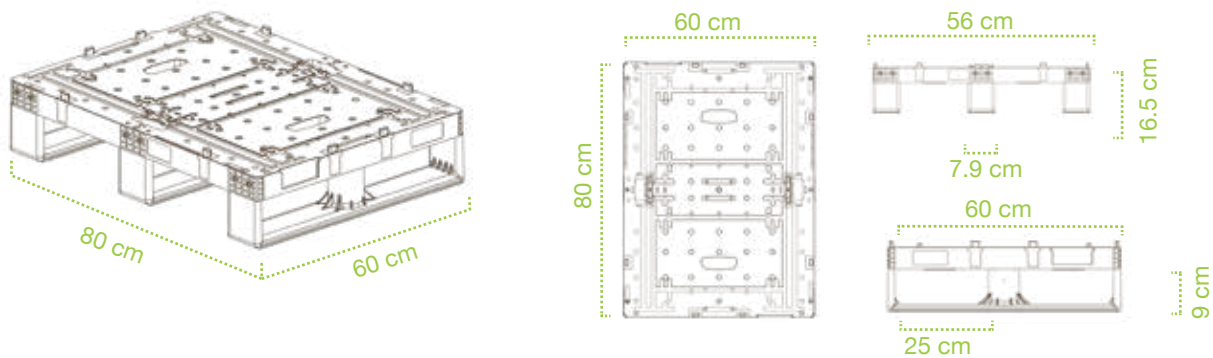

Dimensions (LxWxH)

80 x 60 x 16.5 cm

Weight: 7.7 kg

Maximum load per unit: 500 kg

Available with or without pop-ups



Retail Ready Packaging
The ultimate in cost savings

Elog & Tosca reserves the right to change any of the above mentioned specifications without prior notice.
user responsibility: It is the responsibility of all users and heirs to inform any other user concerning the details provided on this specifications sheet and the Elog & Tosca Health & Safety Guidelines. Users are responsible for completing Safe System Work and risk assessment prior to equipment use.